

ZR Series

ZR14™, ZR22™, and ZR24™ LED Troffers

Rev. Date: V10 02/07/2023

Product Description

The ZR LED troffer provides energy productivity and code compliance – all with installation that’s so intuitive and simple. The ZR Series delivers from 2,000 to 10,000 lumens and 80 CRI quality light and is perfect for both new construction and renovation. Multiple control options including 0-10V, SmartCast® Technology, Lutron Vive, and Lutron EcoSystem products incorporate integrated ambient and occupancy sensing and wireless communication resulting in lower electricity bills, reduced maintenance and an improved total cost of ownership over traditional lighting control systems. The ZR LED troffer embodies a breakthrough in balancing energy savings, visual comfort and project budgets.

Performance Summary

Efficacy: Up to 144 LPW
Initial Delivered Lumens: 2,030 to 10,125 (see table below)
Input Power: 15W-75W
CRI: 85*
CCT: 3000K, 3500K, 4000K, 5000K
Input Voltage: 120-277 VAC, 347VAC
Limited Warranty*: 5 years on luminaire; 5 years on SmartCast® and Lutron controls; up to 5 years for SmartCast® accessories; 1 year for luminaire accessories
Limited Warranty Emergency Back Up (EB) Battery: 1 year on Battery Back Up. Test regularly in accordance with local code
Controls: 0-10V, SmartCast Wireless, Lutron Vive, Lutron EcoSystem

Mounting: Recessed [Designed for use in most ceiling grids including standard 1 1/2", 9/16", 15/16", hard ceiling, and surface mounting]

* CRI can vary +/-5% depending on CCT.
 * See <http://creelighting.com/warranty> for warranty terms. For SmartCast accessories, consult SmartCast spec sheets for details on warranty terms.

Accessories

Field-Installed		
Drywall Grid Adapter DGA14-WHT 1x4, Single Pack DGA14-WHT-10PK 1x4, 10-Pack DGA22-WHT 2x2, Single Pack DGA22-WHT-10PK 2x2, 10-Pack DGA24-WHT 2x4, Single Pack DGA24-WHT-10PK 2x4, 10-Pack	SmartCast® Technology Face Plates CFP-1-WH - Matching face plate, 1-gang, white CFP-2-WH - Matching face plate, 2-gang, white CFP-3-WH - Matching face plate, 3-gang, white	SmartCast® Technology Wireless Plug Load Controller CPLC-JB-CWC SmartCast® Touchscreen Control CSC-TS-A-BK SmartCast® Wireless Gateway with Wi-Fi CSC-GW-CWC-W - Required with SmartCast Touchscreen Control
Surface Mount Kit - Not for use with EB SMK-ZR14 (1x4) SMK-ZR22 (2x2) SMK-ZR24 (2x4)	SmartCast® Technology Wireless Dimmer CSC-CWD-UNVN-WH (neutral wire required) CSC-CWD-UNV-WH (no neutral required) SmartCast® Technology Wireless Switch CSC-CWS-UNVN-WH (neutral wire required) CSC-CWS-UNV-WH (no neutral required)	SmartCast® Wall Plug Power Supply CSC-WPS-120V - For use with SmartCast Wireless Gateway with Wi-Fi SmartCast® Ceiling Plug Power Supply CSC-CPS-120V - For use with SmartCast Wireless Gateway with Wi-Fi
SmartCast® Technology Configuration Tool CCT-CWC-1 - One required per project when SC1 control is selected	SmartCast® 5-Button Wireless Scene Controller CSC-SC-5B-CWC-WH (w/o text) CSC-SC-5S-CWC-WH (w/scene text) CSC-SC-5X-CWC-WH (w/custom text)	SmartCast® 10V Zone Controller CSC-ZC-10V-CWC - Intelligent sensing and control of 0-10V luminaires

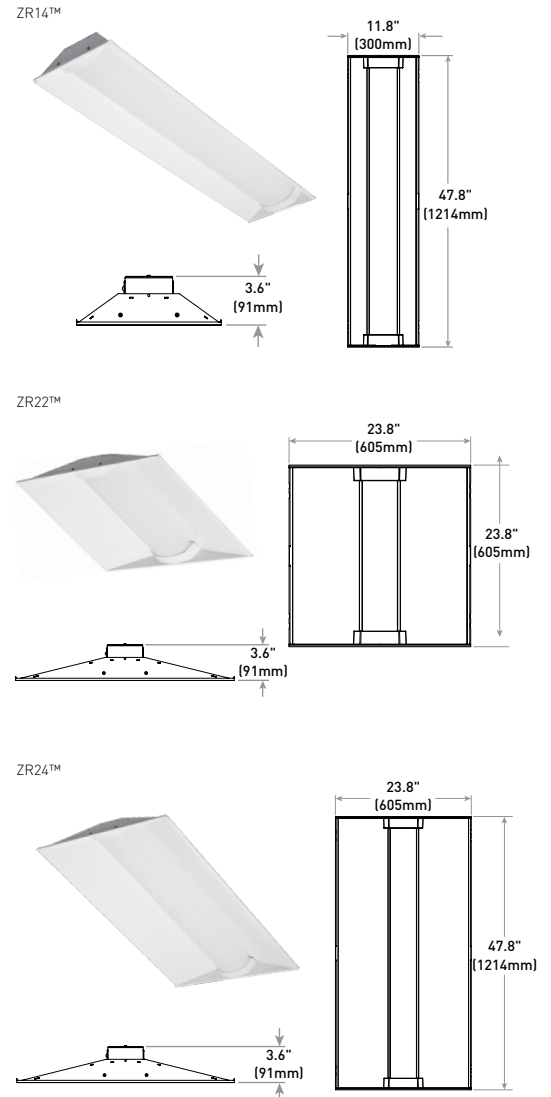

Ordering Information

Example: ZR24-60L-835-SC1-UNV

Series	Size	Lumen Package		CRI/CCT	Lens	Control	Voltage	Factory Installed Options*
ZR	14	30L	50L	830 80 CRI, 3000K	Blank ZR Curve	10V5 - 0-10V 5% Dimming	UNV - Universal 120-277V	EB Emergency Backup - Available with UNV voltage only - Provides 90 minutes of emergency operation
		40L	60L					
		3,490 Lumens	4,940 Lumens					
	22	20L	40L	835 80 CRI, 3500K	Blank ZR Curve	SC1 - SmartCast Wireless Technology with 1% Dimming, Integral motion and ambient sensors	34 - 347V (120-347V only when ordered with 10V5) - Available only with 10V5 control	
		30L	50L					
		2,030 Lumens	4,040 Lumens					
	24	30L	70L	840 80 CRI, 4000K	Blank ZR Curve	VDO† - Lutron Vive Wireless Integral Fixture Control with Occupancy and Daylight Sensing	34 - 347V (120-347V only when ordered with 10V5) - Available only with 10V5 control	
		40L	80L					
		3,490 Lumens	4,940 Lumens					
		50L	100L	850 80 CRI, 5000K	Blank ZR Curve	VRF† - Lutron Vive Wireless Integral Fixture Control (RF only)	34 - 347V (120-347V only when ordered with 10V5) - Available only with 10V5 control	
		60L	150L					
		5,600 Lumens	10,125 Lumens					
		60L	150L	850 80 CRI, 5000K	Blank ZR Curve	LDE1† - Lutron HiLume 1% EcoSystem LED Driver with Soft-on, Fade to Black dimming technology	34 - 347V (120-347V only when ordered with 10V5) - Available only with 10V5 control	
		60L	150L					
		6,150 Lumens	10,125 Lumens					

*Consult factory for other options.
 *More information on Lutron controls can be found at lutron.com.

Product Specifications

SMARTCAST® TECHNOLOGY

SmartCast® Technology is the most intuitive and easiest to install intelligent light solution on the market. SmartCast Technology delivers up to 70% energy savings at up to half the cost of other solutions. Luminaires combine best-in-class light with onboard sensors and intelligence to deliver a better light experience. Extreme energy productivity, code compliance and a better light experience without any extra design, installation or setup work.

CONSTRUCTION & MATERIALS

- Durable 22 ga. cold rolled steel housing provides strength and uniformity
- Ultra-thin 3.6" (91mm) fixture height and lightweight design effectively target a broad range of plenum spaces and allow for easy installations
- Luminaire is post-painted for enhanced smooth matte finish
- Includes integrated hooks for mounting to t-bar, and cable slots for suspended mounting
- Luminaire sides and ends are hemmed in for safe, easy handling
- Room-side accessible/removable lens snaps and locks into end caps for tool-less entry
- Not for installation within 3" (76mm) of insulation
- **Weight: Standard:** 1x4 - 6.6 lbs. (3.0kg); 2x2 - 6.4 lbs. (2.9kg); 2x4 - 11.2 lbs. (5.1kg); **EB:** 1x4 - 10.1 lbs. (4.6kg); 2x2 - 9.2 lbs. (4.2kg); 2x4 - 14.1 lbs. (6.4kg)

OPTICAL SYSTEM

- Unique luminaire design creates perfect balance of both horizontal and vertical illumination
- Optimized smooth acrylic lens eliminates pixelation and delivers a low-glare, diffused light distribution

ELECTRICAL SYSTEM

- **Power Factor:** = 0.9 nominal
- **Input Power:** Stays constant over life
- **Input Voltage:** 120-277V, 347V, 60Hz
- **Operating Temperature Range:** 0°C - + 35°C (32°F - + 95°F)
- **Total Harmonic Distortion:** <20%
- **Dimming:** 1%-100% (Varies by control)

REGULATORY & VOLUNTARY QUALIFICATIONS

- cULus Listed (UL1598 & UL8750)
- Meets NEMA C82.77 standards
- Suitable for damp locations
- Designed for indoor use only
- Requires minimum 90°C supply conductors
- UL924 (EB Option) Maximum mounting height: 15.0' (4.6m)
- EB option meets CA Title 20 Appliance Regulations
- RoHS compliant. Consult factory for additional details
- Meets FCC Part 15, Subpart B, Class A limits for conducted and radiated emissions
- DLC qualified versions available. Please refer to <https://apl.designlights.org/solid-state-lighting> for most current information

- **CA RESIDENTS WARNING:** Cancer and Reproductive Harm - www.p65warnings.ca.gov

SmartCast® Technology

INTEGRAL MOTION SENSOR

- Passive infrared (PIR)
- **Coverage area:** Please refer to the PIR motion sensor coverage table
- Not intended to be mounted higher than 20 ft.
- **Operation:**
 - Grouped with a wall control: Luminaire will operate in vacancy mode (manual-on/auto-off)
 - Not grouped with a wall control: Luminaire will operate in occupancy mode (auto-on/auto-off)
- Luminaires operate at full intensity until OneButton™ Setup is initiated by the Cree Configuration Tool

AMBIENT LIGHT SENSOR

- Sensor response matches response of human eye
- Not intended to be mounted higher than 20 ft. (6.1m)
- Luminaires operate at full intensity until OneButton™ Setup is initiated by the Cree Configuration Tool
- Daylight harvesting calibration performed automatically during OneButton™ Setup

INTEGRAL WIRELESS COMMUNICATION

- 2.4GHz wireless mesh technology with AES 128-bit encryption
- Self assigns to quietest channel during OneButton™ Setup
- **Range:**
 - 30 ft. (9.1m) in typical commercial applications
 - 300 ft. (91.4m) open air without obstructions
- **Network:** 250 devices max.
- **Space:** 100 devices max. per group
- FCC and IC certifications

LUMINAIRE

- Energy metering with 4% accuracy
- Luminaires operate at full intensity until OneButton™ Setup is initiated by the Cree Configuration Tool
- 10 year power fail memory of settings
- **NOTE:** SmartCast luminaires must be installed on unswitched AC power. Constant power is required to maintain all luminaires on the SmartCast network. If wall control or manual dimming is required, a SmartCast wall control dimmer must be used for manual on, off, and dimming.

DEPLOYMENT

- Please refer to the SmartCast® Deployment Guide at <https://cree.widen.net/s/mvxtfd2pcz/smartcast-wireless-deployment-guide>

PIR Motion Sensor Coverage

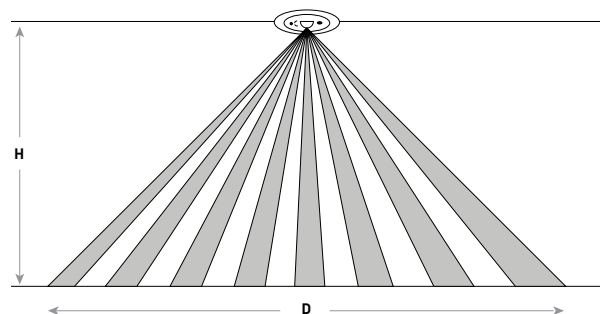

Mounting Height - H (Feet)	Motion Sensor Coverage Diameter - D (Feet)		
	Sensitivity - High (Default)	Sensitivity - Medium	Sensitivity - Low
10	20	10	8
12	26	14	12
14	28	15	13
20	38	Not Recommended	Not Recommended

Delivered Lumens & Electrical Data*									
Size	Lumen Package	Delivered Lumens	Delivered Lumens	System Watts 120-277V/347V	Total Current (A)				
					120V	208V	240V	277V	347V
2X2	20L	10V5	2,030	15	0.12	0.07	0.06	0.06	0.05
		10V5 w/EB			0.13	0.09	0.08	0.06	N/A
		SC1, VDO, VRF, LDE1, LDE5			0.20	0.08	0.07	0.06	N/A
1X4/2X2/2X4	30L	10V5	3,490	26	0.21	0.12	0.11	0.10	0.08
		10V5 w/EB			0.25	0.14	0.13	0.12	N/A
		SC1, VDO, VRF, LDE1, LDE5			0.30	0.13	0.11	0.10	N/A
1X4/2X2/2X4	40L	10V5	4,040	29	0.25	0.14	0.12	0.11	0.09
		10V5 w/EB			0.29	0.16	0.14	0.13	N/A
		SC1, VDO, VRF, LDE1, LDE5			0.34	0.14	0.13	0.11	N/A
1X4/2X2	50L	10V5	4,940	36	0.31	0.17	0.15	0.13	0.11
		10V5 w/EB			0.35	0.19	0.17	0.15	N/A
		SC1, VDO, VRF, LDE1, LDE5			0.40	0.18	0.16	0.14	N/A
2X4	50L	10V5	5,600	41	0.35	0.20	0.17	0.15	0.12
		10V5 w/EB			0.39	0.22	0.19	0.17	N/A
		SC1, VDO, VRF, LDE1, LDE5			0.45	0.19	0.17	0.15	N/A
1X4/2X4	60L	10V5	6,150	44	0.38	0.21	0.19	0.16	0.13
		10V5 w/EB			0.41	0.23	0.20	0.18	N/A
		SC1, VDO, VRF, LDE1, LDE5			0.49	0.22	0.19	0.17	N/A
2X4	70L	10V5	6,750	47	0.40	0.23	0.20	0.17	0.16
		10V5 w/EB			0.45	0.26	0.23	0.20	N/A
		SC1, VDO, VRF, LDE1, LDE5			0.49	0.24	0.21	0.18	N/A
2X4	80L	10V5	8,275	62	0.52	0.30	0.26	0.23	0.19
		10V5 w/EB			0.57	0.31	0.27	0.25	N/A
		SC1, VDO, VRF, LDE1, LDE5			0.66	0.29	0.26	0.23	N/A
2X4	100L	10V5	10,125	74	0.63	0.36	0.31	0.27	0.22
		10V5 w/EB			0.63	0.36	0.32	0.27	N/A
		SC1, VDO, VRF, LDE1, LDE5			0.72	0.35	0.30	0.27	N/A

* Electrical data at 25°C (77°F). Actual wattage and lumens may differ by +/- 10% when operating between 120-277V or 347V +/- 10%.

Delivered Emergency Lumens		
Size	Lumen Package	Approximate Delivered Emergency Lumens
2X2	20L	1,620
1X4/2X2/2X4	30L	1,400
	40L	1,430
1X4/2X2	50L	1,410
2X4	50L	1,490
1X4/2X4	60L	1,480
2X4	70L	1,470
2X4	80L	1,460
2X4	100L	1,620

ZR Series Ambient Adjusted Lumen Maintenance ¹					
	Initial LMF	25K hr Reported ² LMF	50K hr Reported ² LMF	75K hr Estimated ³ LMF	100K hr Estimated ³ LMF
25°C (77°F)	1.00	0.95	0.90	0.85	0.81

¹ Lumen maintenance values at 25°C (77°F) are calculated per IES TM-21 based on IES LM-80 report data for the LED package and in-situ luminaire testing. Luminaire ambient temperature factors (LATF) have been applied to all lumen maintenance factors.
² In accordance with IES TM-21, Reported values represent interpolated values based on time durations that are up to 6x the tested duration in the IES LM-80 report for the LED.
³ Estimated values are calculated and represent time durations that exceed the 6x test duration of the LED.

Photometry

ZR14-40L-830-10V5-UNV BASED ON TEST REPORT #: STD200105NB-AB

Luminaire photometry has been conducted in accordance with IES LM-79. IES LM-79 specifies the entire luminaire as the source resulting in a luminaire efficiency of 100%.

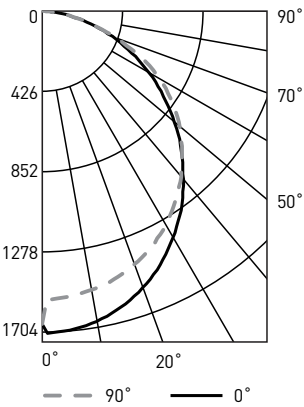

Coefficients Of Utilization – Zonal Cavity Method				
RC %:	80			
RW %:	70	50	30	10
RCR: 0	119	119	119	119
1	109	104	100	96
2	99	90	83	78
3	90	79	71	64
4	82	70	61	54
5	76	63	54	47
6	70	56	47	41
7	65	51	42	36
8	60	47	38	32
9	56	43	34	29
10	53	39	31	26

Effective Floor Cavity Reflectance: 20%

Average Luminance Table (cd/m ²)			
Vertical Angle	Horizontal Angle		
	0°	45°	90°
45°	3,471	3,912	4,154
55°	3,187	3,750	4,114
65°	2,844	3,583	3,980
75°	2,311	3,235	3,296
85°	1,306	2,021	1,965

Zonal Lumen Summary			
Zone	Lumens	% Lamp	Luminaire
0-30	1,078	N/A	27.1%
0-40	1,766	N/A	44.4%
0-60	3,120	N/A	78.5%
0-90	3,973	N/A	99.9%
0-180	3976	N/A	100%

Application Reference

Open Space						
Spacing	Lumen Package	Initial Delivered Lumens	Wattage	LPW	w/ft ²	Average fc
8 x 8	30L	3,490	26	134	0.39	51
	40L	4,040	29	139	0.44	59
	50L	4,940	36	137	0.54	72
	60L	6,150	44	140	0.66	89
8 x 10	30L	3,490	26	134	0.33	42
	40L	4,040	29	139	0.37	48
	50L	4,940	36	137	0.46	59
	60L	6,150	44	140	0.56	74
10 x 10	30L	3,490	26	134	0.26	33
	40L	4,040	29	139	0.29	38
	50L	4,940	36	137	0.36	47
	60L	6,150	44	140	0.44	58
10 x 12	30L	3,490	26	134	0.21	26
	40L	4,040	29	139	0.24	30
	50L	4,940	36	137	0.29	37
	60L	6,150	44	140	0.36	46

10' ceiling: 80/50/20 reflectances; 2.5' workplane, open room. LLF: 1.0 Initial Open Space: 50' x 40' x 10

Reference <https://www.creelighting.com/products/indoor/troffers/zr-series> for detailed photometric data.

Photometry

ZR22-30L-830-10V5-UNV BASED ON TEST REPORT #: STD200105NB-BB

Luminaire photometry has been conducted in accordance with IES LM-79. IES LM-79 specifies the entire luminaire as the source resulting in a luminaire efficiency of 100%.

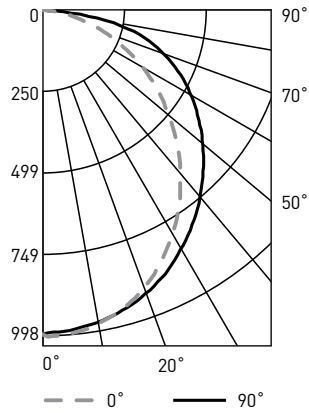

Coefficients Of Utilization – Zonal Cavity Method				
RC %:	80			
RW %:	70	50	30	10
RCR: 0	119	119	119	119
1	108	103	99	95
2	98	89	82	76
3	89	78	70	63
4	82	69	60	53
5	75	62	53	46
6	69	56	46	40
7	64	50	41	35
8	60	46	37	31
9	56	42	34	28
10	52	39	31	26

Effective Floor Cavity Reflectance: 20%

Average Luminance Table (cd/m²)				
Vertical Angle	Horizontal Angle			
	0°	45°	90°	
45°	2,892	3,214	3,484	
55°	2,640	3,142	3,570	
65°	2,335	3,150	3,821	
75°	1,880	3,273	4,203	
85°	971	2,631	3,113	

Reference <https://www.creelighting.com/products/indoor/troffers/zr-series> for detailed photometric data.

Zonal Lumen Summary			
Zone	Lumens	% Lamp	Luminaire
0-30	905	N/A	26.4%
0-40	1,476	N/A	43.2%
0-60	2,609	N/A	76.3%
0-90	3,419	N/A	100%
0-180	3,420	N/A	100%

Application Reference

Open Space						
Spacing	Lumen Package	Initial Delivered Lumens	Wattage	LPW	w/ft²	Average fc
8 x 8	20L	2,030	15	135	0.23	29
	30L	3,490	26	134	0.39	50
	40L	4,040	29	139	0.44	58
	50L	4,940	36	137	0.54	71
8 x 10	20L	2,030	15	135	0.19	24
	30L	3,490	26	134	0.33	41
	40L	4,040	29	139	0.37	48
	50L	4,940	36	137	0.46	59
10 x 10	20L	2,030	15	135	0.15	19
	30L	3,490	26	134	0.26	33
	40L	4,040	29	139	0.29	38
	50L	4,940	36	137	0.36	46
10 x 12	20L	2,030	15	135	0.12	15
	30L	3,490	26	134	0.21	26
	40L	4,040	29	139	0.23	30
	50L	4,940	36	137	0.29	37

10' ceiling; 80/50/20 reflectances; 2.5' workplane, open room. LLF: 1.0 Initial Open Space: 50' x 40' x 10'

Photometry

ZR24-40L-830-10V5-UNV BASED ON TEST REPORT #: STD200105NB-CB

Luminaire photometry has been conducted in accordance with IES LM-79. IES LM-79 specifies the entire luminaire as the source resulting in a luminaire efficiency of 100%.

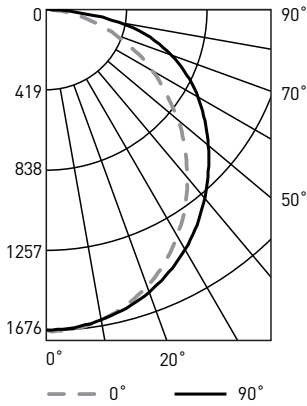

Coefficients Of Utilization – Zonal Cavity Method				
RC %:	80			
RW %:	70	50	30	10
RCR: 0	119	119	119	119
1	108	103	98	94
2	98	89	82	76
3	89	78	70	63
4	81	69	60	53
5	75	61	52	45
6	69	55	46	40
7	64	50	41	35
8	59	46	37	31
9	56	42	34	28
10	52	39	31	25

Effective Floor Cavity Reflectance: 20%

Average Luminance Table (cd/m²)			
Vertical Angle	Horizontal Angle		
	0°	45°	90°
45°	1,620	1,850	1,995
55°	1,480	1,807	2,042
65°	1,311	1,818	2,180
75°	1,061	1,903	2,374
85°	626	1,595	1,583

Zonal Lumen Summary			
Zone	Lumens	% Lamp	Luminaire
0-30	1,039	N/A	26.1%
0-40	1,700	N/A	42.7%
0-60	3,018	N/A	75.8%
0-90	3,980	N/A	100%
0-180	3,982	N/A	100%

Reference <https://www.creelighting.com/products/indoor/troffers/zr-series> for detailed photometric data.

Application Reference

Open Space						
Spacing	Lumen Package	Initial Delivered Lumens	Wattage	LPW	w/ft²	Average fc
8 x 8	30L	3,490	26	134	0.39	51
	40L	4,040	29	139	0.44	59
	50L	5,600	41	137	0.62	81
	60L	6,150	44	140	0.66	89
	70L	6,750	47	144	0.71	98
	80L	8,275	62	133	0.93	120
	100L	10,125	74	137	1.11	147
8 x 10	30L	3,490	26	134	0.33	41
	40L	4,040	29	139	0.37	47
	50L	5,600	41	137	0.53	66
	60L	6,150	44	140	0.56	72
	70L	6,750	47	144	0.60	79
	80L	8,275	62	133	0.79	97
	100L	10,125	74	137	0.95	119
10 x 10	30L	3,490	26	134	0.26	33
	40L	4,040	29	139	0.29	38
	50L	5,600	41	137	0.41	53
	60L	6,150	44	140	0.44	58
	70L	6,750	47	144	0.47	64
	80L	8,275	62	133	0.62	79
	100L	10,125	74	137	0.74	96
10 x 12	30L	3,490	26	134	0.21	26
	40L	4,040	29	139	0.24	30
	50L	5,600	41	137	0.33	42
	60L	6,150	44	140	0.36	46
	70L	6,750	47	144	0.38	51
	80L	8,275	62	133	0.50	62
	100L	10,125	74	137	0.60	76

10' ceiling; 80/50/20 reflectances; 2.5' workplane, open room. LLF: 1.0 Initial Open Space: 50' x 40' x 10'

© 2023 Cree Lighting, A company of IDEAL Industries. All rights reserved. For informational purposes only. Content is subject to change. Patent www.cree.com/patents. Cree® and the Cree Lighting logo are registered trademarks of Cree, Inc. SmartCast® and the SmartCast logo are registered trademarks, and ZR14™, ZR22™, ZR24™ and OneButton™ are trademarks of Cree Lighting, A company of IDEAL INDUSTRIES. The UL logo is a registered trademark of UL LLC. Lutron, the Lutron logo, EcoSystem, the Lutron EcoSystem Enabled logo and Vive are trademarks or registered trademarks of Lutron Electronics Co., Inc. The DLC QPL and the DLC LUNA Logos are the registered and unregistered trademarks of Efficiency Forward, Inc.



A COMPANY OF IDEAL INDUSTRIES, INC.

US: creelighting.com T (800) 236-6800 F (262) 504-5415
 Canada: creelighting-canada.com T (800) 473-1234 F (800) 890-7507